



## Professional LED Street & Area Lighting











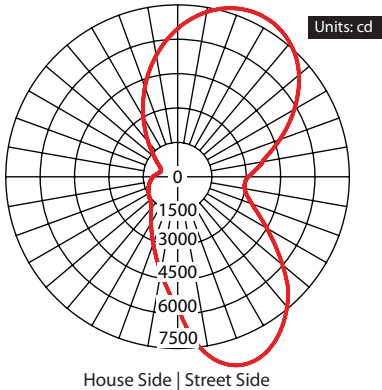
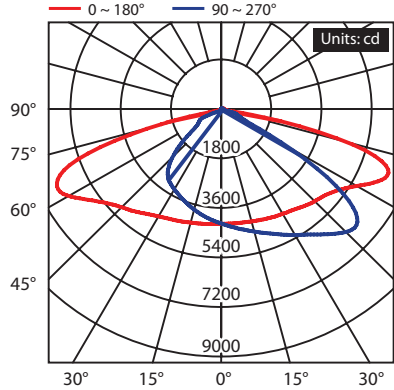
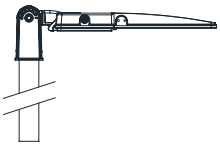

LSL-B Series: Street and area lighting available in 100W, 150W and 200W

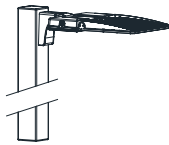
The ENSA™ LSL-B Series comprises versatile LED lights with a variety of mounting and sensor options to deliver high performance street and area lighting. These luminaires offer impressive lighting with high energy efficiency in a robust slimline housing. LSL-B Series lights feature a wide range of mounting solutions to fit to a multitude of installation requirements. Models also feature the option for built-in dusk/dawn switching and motion detection by passive infrared or microwave sensors.

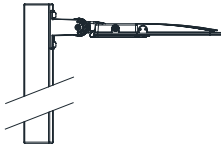
LSL-B Series lights are ideal for illumination in street lighting applications, in area lighting for public spaces and for general purpose lighting in a variety of commercial and industrial building environments.

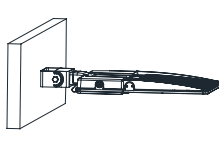
- High luminous efficacy up to 135lm/W
- Batwing or square distribution for street & area lighting
- Long lifespan LED lighting: rated for up to 50,000 hours
- Rotate polycarb lens for easy light direction adjustment
- Includes in-line surge protection for up to 20KV
- Robust IP66/IK08 weather & vandal resistant housing
- Photocell & PIR / microwave motion sensor optional
- Versatile mounting with 5 adjustable brackets (sold separately)

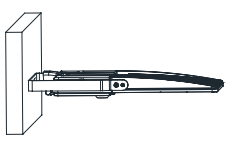
## Series Specifications

Model	LSL-B100	LSL-B150	LSL-B200		
Product Image					
Series Name	LSL-B Series: LED Street Lights				
<b>Optical</b>					
Light Output	13,500lm	20,250lm	27,000lm		
Luminous Efficacy	135lm/W				
Colour Temperature	5000K				
Colour Rendering Index	70				
Beam Angle	155° x 85°				
Light Decay	23% at 50,000 hours				
Rated Lifespan	50,000 hours				
<b>Electrical</b>					
Power Consumption	100W	150W	200W		
Input Voltage	100 ~ 277VAC				
Power Factor	> 0.93				
Dimmable	1 ~ 10V / PWM				
<b>General</b>					
Ingress Protection	IP66				
Vandal Resistance	IK08				
Plug / Socket / Base	Unterminated				
Reflector / Diffuser	Clear polycarbonate Lens				
Operating Environment	-20° ~ 50°C				
Pole Diameter	Ø62.1mm (LSL-BKTS *sold separately)				
Dimensions	428 x 247 x 55mm	428 x 247 x 55mm	458 x 268 x 55mm		
<b>Photometry</b>					
Max Intensity Distribution (150W)	 <p>Units: cd</p> <p>House Side   Street Side</p>		 <p>Units: cd</p> <p>Luminous Light Distribution (150W)</p>		
Brackets	  Slip Fitter Adjustable LSL-BKTS	  Fixed Pole Mount LSL-BKTP	  Adjustable Pole Mount LSL-BKTA	  Trunnion Mount LSL-BKTT	  Yoke Wall Mount LSL-BKTY

## Ordering Information

Type	Series	Wattage	Colour Temperature	Sensors
LSL	- B	100 (100W) 150 (150W) 200 (200W)	C (Cool white)	S (Motion sensing) P (Photocell)
LSL-B150-CS: 150W LED Street Light in Cool White with Motion Sensing				